

LUMINO CITY™ ALTERNATIVE BRACKETS INSTALLATION INSTRUCTIONS



Ensure that personnel carrying out this conversion have the relevant qualifications/certificates and all work is carried out in accordance with BS7671:2008/I.E.E. Wiring Regulations 17th Edition (IET Amendment 3:2015). Ensure that all relevant personnel read the points listed within this leaflet and that a copy is given to staff involved with the installation and maintenance of this product.

Glasdon recommends that a full Health and Safety analysis is carried out prior to installation.

KIT CONTENTS

Kit 1	ITEM 1 - Sign Light and Top Bracket (750 or 1500)	x 1	
Kit 2	ITEM 2 - Sign Light and Clamp Bracket (750 or 1500)	x 1	
	ITEM 3 - Bracket Clamp Rear	x 1	
	ITEM 4 - M8 x 30mm Socket Head Screw	x 4	
	ITEM 5 - M8 x 25mm Washer	x 4	
	ITEM 6 - M8 Nyloc Nut	x 4	
Kit 3	ITEM 7 - Sign Light Unit (750 or 1500)	x 1	
	ITEM 8 - Bracket Disc Cap	x 2	
	ITEM 9 - M10 x 80mm Socket Head Screw	x 1	
	ITEM 10 - Nylon Washer M10 x 18mm	x 1	
	ITEM 11 - Rubber Washer M10 x 18mm	x 1	
	ITEM 12 - Post Clamp Bracket (Ø76mm or Ø114mm)	x 1	
	ITEM 13 - Universal Bracket	x 1	
	ITEM 14 - M8 x 20mm Screw	x 3	
	ITEM 15 - M8 x 20mm Washer	x 2	
Ø76 and Ø114 ITEMS	ITEM 16 - M6 x 60mm Skt Screw	x 4	
Ø76 ONLY	ITEM 17 - M6 Washer	x 4	
	ITEM 18 - M6 Nyloc Nut		
	ITEM 17 - M6 Washer	x 4	
Ø114 ONLY	ITEM 19 - M6 x 16mm Skt Screw	x 4	
	ITEM 20 - M6 Cap Ring	x 4	
	ITEM 21 - M6 Rubber Washer	x 4	
	ITEM 22 - M6 Cover Cap	x 4	

BRACKET COMPATIBILITY

POST SIZE		Ø76	Ø89	Ø114
KIT 1	Top Post Offset	•		
KIT 2	Mid Post Clamp Offset	•		
KIT 3	Mid Post Clamp	•		•

Double Sided Unit

x 2

x 4

x 2

x 2

x 2

(Double version)

x 2

x 6

x 4

x 4

x 8

x 4

x 4

x 4

x 4

x 4

x 4

EQUIPMENT REQUIRED

- Relevant Safety Equipment
- Tape Measure
- Drill
- 12mm metal Drill Bit
- Pen

Allen Key 4mm x 1

Allen Key 6mm x 1

(Included with all kits.)

Kit 1 - Top Post Offset Bracket Mounting Kit

- Remove any top cap or existing sign light attached to the post.
- Feed the cable from the Lumino City down the inside of the post from the top.
- Ensure the grub screws fitted to the bracket (ITEM 1) are unscrewed far enough to allow the bracket to fit over the post.
- Place the bracket over the top of the post as shown in Fig. 1.
- Loosely tighten the 3 x grub screws in the bracket evenly until the desired position is achieved.
- Tighten the grub screws firmly to grip the bracket onto the post securely.

- Wire the cable into the cut out and finally reconnect the power and secure access door.

NOTE: For the Lumino City 24V unit ensure a 24V ac transformer is used.

FIG. 1

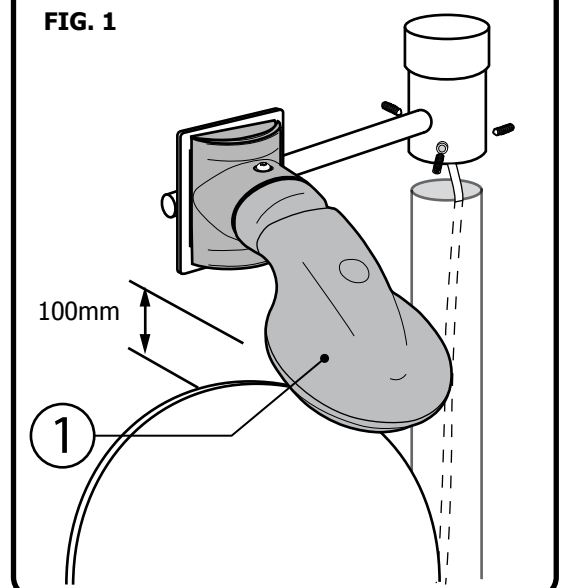

Kit 2 - Mid Post Offset Clamp Bracket Mounting Kit

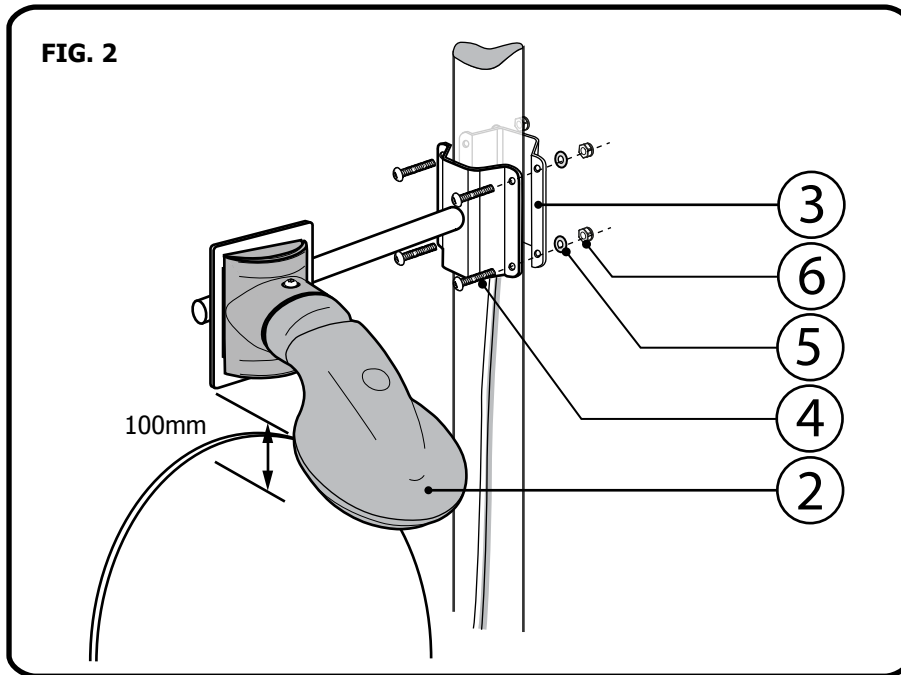

- Loosely install the sign light and bracket (ITEM 2) in the approximate position where it will be positioned over the sign using ITEM's 4, 5 and 6 (without tightening the fixings fully yet). Position the sign light 100mm above the top of the sign face (see Fig. 2). Be careful not to trap the cable between the post and bracket.

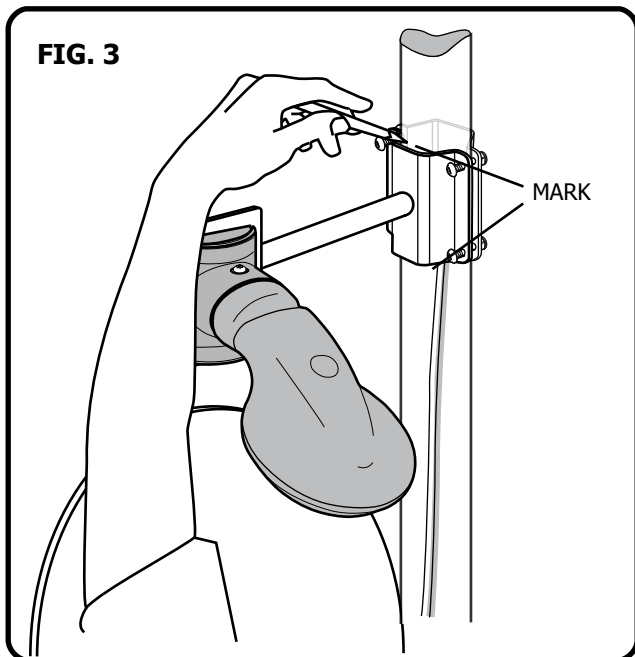

- With the product in the desired final position - mark on the post the position of the top and bottom of the bracket using chalk / pen (see Fig. 3).
- Remove the sign light and bracket from the post.
- Measure the distance between the two lines you have just marked. At a point midway between the two mark the location for the hole to be drilled in the post (see Fig. 4).

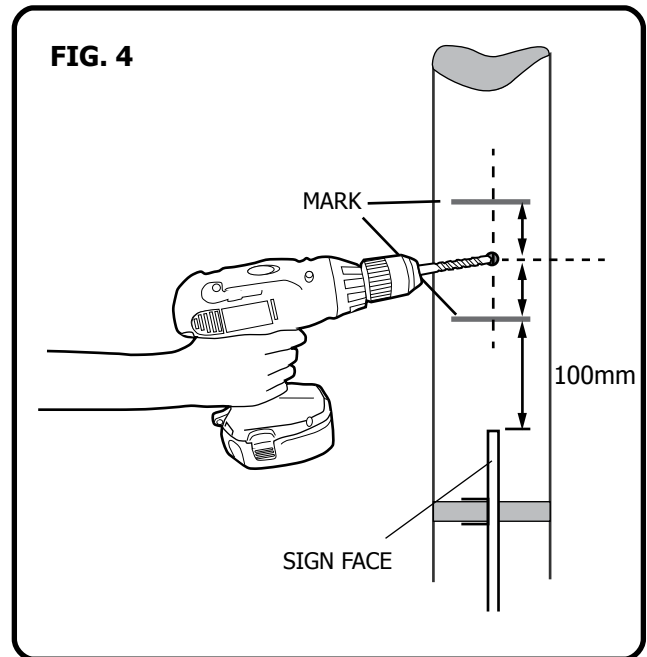

- Ensure this is perpendicular to the post and aligned with the sign face.
- Drill a $\text{Ø}12\text{mm}$ hole in the post in the position marked. A 12mm hole is recommended as a minimum - although a larger hole can be drilled.

NOTE: Deburr the hole to prevent any sharp edges damaging the electrical cable during installation.

FIG. 5

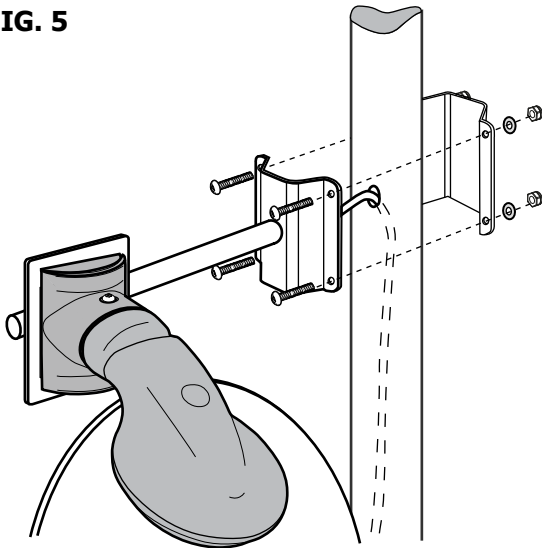

- Feed the wire from the sign light directly into the hole in the post just drilled. Feed it all the way in from the top (do not pull from the bottom as this may damage the wire if scraped against the hole in the post).

- Secure the bracket in place (see Fig. 5). It may require 2 people - with one supporting the weight of the bracket and feeding the M8 screws (ITEM 4) through from one bracket - with the other securing the rear bracket (ITEM 3) using the M8 washers (ITEM 5) and M8 nuts (ITEM 6).

NOTE: If necessary - make minor adjustments to the position of the sign by laterally moving it to ensure the sign face is central to the Lumino City.

- Wire the cable into the cut out and finally reconnect the power and secure access door.

NOTE: For the Lumino City 24V unit ensure a 24V ac transformer is used.

Kit 3 - Mid Post Clamp Bracket Mounting Kit - Ø76mm and Ø114mm

FIG. 6

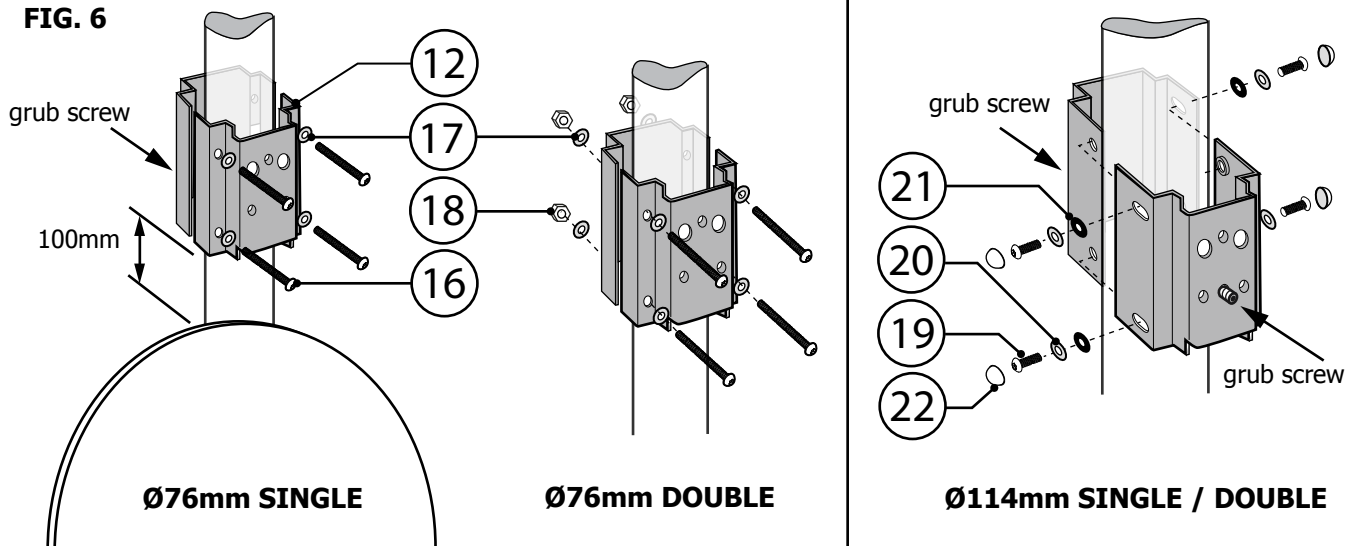

Ø76mm SINGLE

- Install the bracket (ITEM 12) onto the post using the screws (ITEM 16) and washers (ITEM 17) (see Fig. 6).

- Adjust the grub screw in the rear bracket to help with grip and alignment to the post (SINGLE version only).

NOTE: Ensure the front half of the bracket (the side with the holes) faces the same orientation as the sign face to be illuminated. Mount the bracket so the bottom is 100mm from the top of the sign face.

Ø76mm DOUBLE: Ensure the bracket is aligned horizontally with the sign face and use the additional 4off washers (ITEM 17) and 4off nuts (ITEM 18) to secure the double bracket in place.

Ø114mm SINGLE / DOUBLE

- Install the bracket (ITEM 12) onto the post using the screws (ITEM 19), rubber washers (ITEM 21) and cap ring (ITEM 20). The bracket should grip the post firmly.

- Adjust the grub screw in the front and rear bracket to help with alignment and grip onto the post.

- Once tightened, the cover caps (ITEM 22) should be 'snapped' over the fixtures to cover them (see Fig. 6).

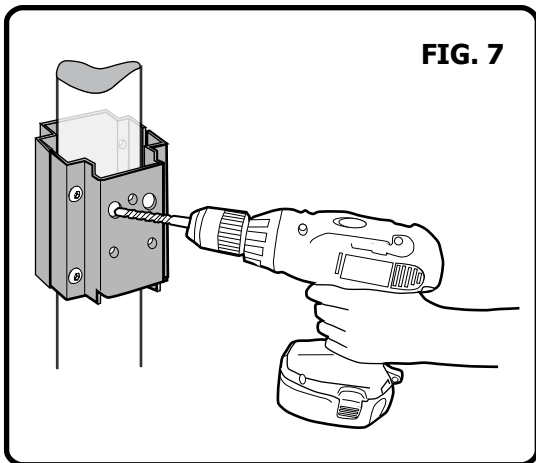

FIG. 7

- Use the bracket (ITEM 12) as a drilling jig to drill a Ø12mm hole through the left hand hole of the bracket (see Fig. 7) into the post. This hole will allow the cable from the sign light to be fed down inside the post.

NOTE: Deburr the hole to prevent any sharp edges damaging the electrical cable during installation.

DOUBLE: Drill a hole on each side of the post.

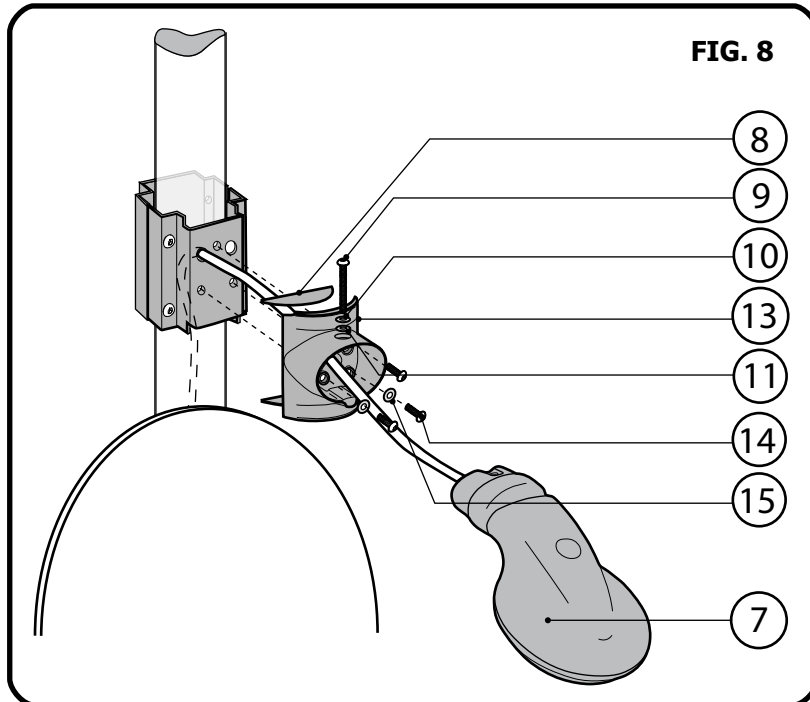

FIG. 8

- Feed the wire from the sign light through the corresponding left hand hole in the universal bracket (ITEM 13) and through the hole in the post just drilled (see Fig. 8). Feed it all the way into the post from the top (do not pull from the bottom as this may damage the wire if scraped against the hole in the post).

- Fit the bracket caps (ITEM 8) into the slots at the top and bottom of the universal bracket (ITEM 13). Fix the universal bracket to the post clamp bracket (ITEM 12) using the 3 off M8 screws (ITEM 14) and 2 off M8 washers (ITEM 15).

- Fit the sign light (ITEM 7) into the universal bracket and secure in place using the M10 screw, nylon washer and rubber washer (ITEM's 9, 10 and 11).

- Wire the cable into the cut out and finally reconnect the power and secure access door.

NOTE: For the Lumino City 24V unit ensure a 24V ac transformer is used.

DOUBLE: Repeat the process to install the second sign light on the opposing side.



Lumino City 750 and 1500 are CE Marked and have been designed to comply with the relevant Standards and Directives for its product classification.

An EC Declaration of Conformity certificate and a copy of the CE Marking Technical File is available from the Glasdon UK Quality Assurance Department upon request.

IMPORTANT NOTE: PLEASE ENSURE THAT ALL RELEVANT PERSONNEL READ THE POINTS LISTED WITHIN THIS LEAFLET AND THAT A COPY IS GIVEN TO STAFF INVOLVED WITH THE INSTALLATION AND MAINTENANCE OF THIS PRODUCT.

SAFETY NOTE: PLEASE REFER TO 'THE MANUAL HANDLING OPERATIONS REGULATIONS 1992' DURING HANDLING.



AND LUMINO CITY ARE TRADEMARKS OR REGISTERED TRADEMARKS OF GLASDON GROUP OR ITS SUBSIDIARIES IN THE U.K AND OTHER COUNTRIES

• A planned maintenance schedule or regular inspection is recommended, replacing components as necessary.

• Replacement components are available direct from GLASDON.

• GLASDON cannot be held responsible for claims arising from incorrect installation, unauthorised modifications or misuse of the product.

Issue 2 December 2015 Stock no. C000/0471 DWG No. 02B-080-74
© Copyright 01/2015

Glasdon UK Ltd reserve the right to alter specifications without prior notice.



Glasdon U.K Limited

Preston New Road
BLACKPOOL
Lancashire FY4 4UL
Tel: 01253 600410
Fax: 01253 792558
email: sales@glasdon-uk.co.uk
web: www.glasdon.com